



Building a better future  
**Global Leader**



**CE**

# HP 160



 **HYUNDAI**  
HEAVY INDUSTRIES CO., LTD.

# HP160

## Manipulator Specifications

Item		Specification	
<b>Model</b>		<b>HP160</b>	
Payload		160 kg	
Structure		Articulated	
Degree of freedom		4 Axes	
Max. Operating Range	S	Swivel	±180 °
	Pallatizing Range	□1400	2,614 mm
		□1600	2,180 mm
R	Rotating	±360 °	
Ability of Operation	Box	1,300 CPH	
	Bag	1,560 CPH	
Allowable Wrist Torque		50 kgf·m	
Allowable Wrist Inertia		78 kgf·m <sup>2</sup>	
Repeatability		±0.5 mm	
Ambient Temperature		0 ~ 45 °C (273 ~ 318 K)	
Approximate Weight		1,400 kg	
Motion Range Section Area		5.76 m <sup>2</sup>	

### Working Envelope

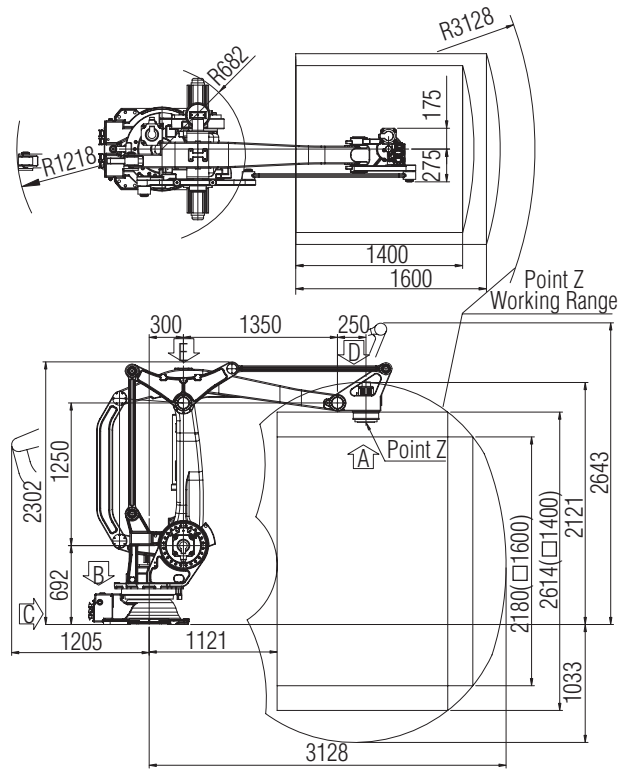

### View "A" For Tool Attachment

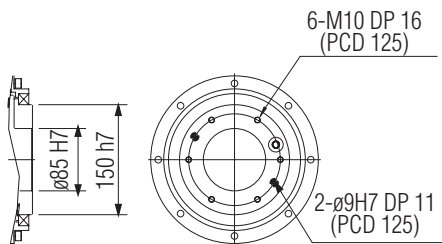

### View "B" For Installation

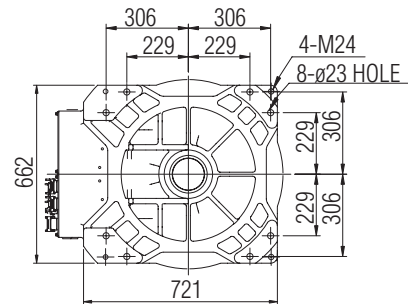

### View "C" For User Application

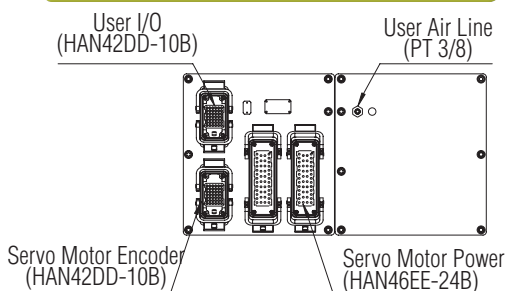

### View "D" For User Application (Option)

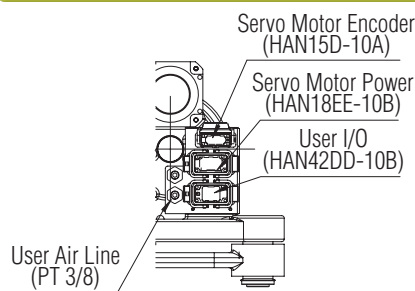

### View "E" For Cable Guide

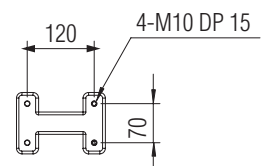

## ■ Controller Specifications

Item	Specification	
<b>Model Name</b>	<b>Hi5</b>	
Control Hardware	Multi Processor System	
Execution Mode	Teaching & Playback	
Interpolation Type	Point-to-Point, Linear, Circular	
Max. Axes	Max. 16 Axes Simultaneously	
Number of Step	17,000 Points	
External Program Selection	Binary 255 / Discrete 8	
Position Detector	Serial Absolute Encoder	
Program Back-up	USB Memory	
Servo Control	Full Digital Servo	
Digital Input / Output	Max. Input : 256 / Output : 256 Points	
Analog Input / Output	Input : 4 ch / Output : 4 ch	
Conveyor Pulse Counter	Differential Input / Open Collector Input, 2ch	
Communication	Ethernet	100BaseT (2 Ports)
	CAN	User1 / User2
	Serial	RS232C, RS422 (RS485)
	Field Bus	CC-Link, Profibus-DP, Devicenet, Modbus
Rated Supply Voltage	AC220V ± 10%, 50 / 60 Hz	
Max. Rated Power	8 kVA (Instant Max. 30 kVA)	
Cabinet Dimension (WxDxH)	650 mm x 600 mm x 1,100 mm (Except Caster)	
Weight	150 kg (Without Transformer)	
Protection Classification	IP54	
Ambient Temperature	0 ~ 45 °C	

## ■ Teaching Pendant Specifications

Item	Specification
Microprocessor	32 bits RISC Processor
Operating System	Windows CE
Display	7" Color TFT-LCD
Operation Mode	Menu Driven and Code Input / Touch Panel

### · Easy and simple operation

- Easy/convenient programming language similar to BASIC

### · Easy maintenance

- Excellent maintenance ability using on-line display function

### · Advanced control technology

- Dynamic control
- Advanced vibration suppression control
- Extended torque-velocity control

### · Safety

- Compliant with ANSI/RIA15.6\_1999 and CE Directives

### · Compatibility and connectivity

- Embedded soft PLC
- Fieldbus : CC-Link, Profibus-DP, Devicenet, Modbus, etc.
- Ethernet, Serial Communication

## ■ System Configuration

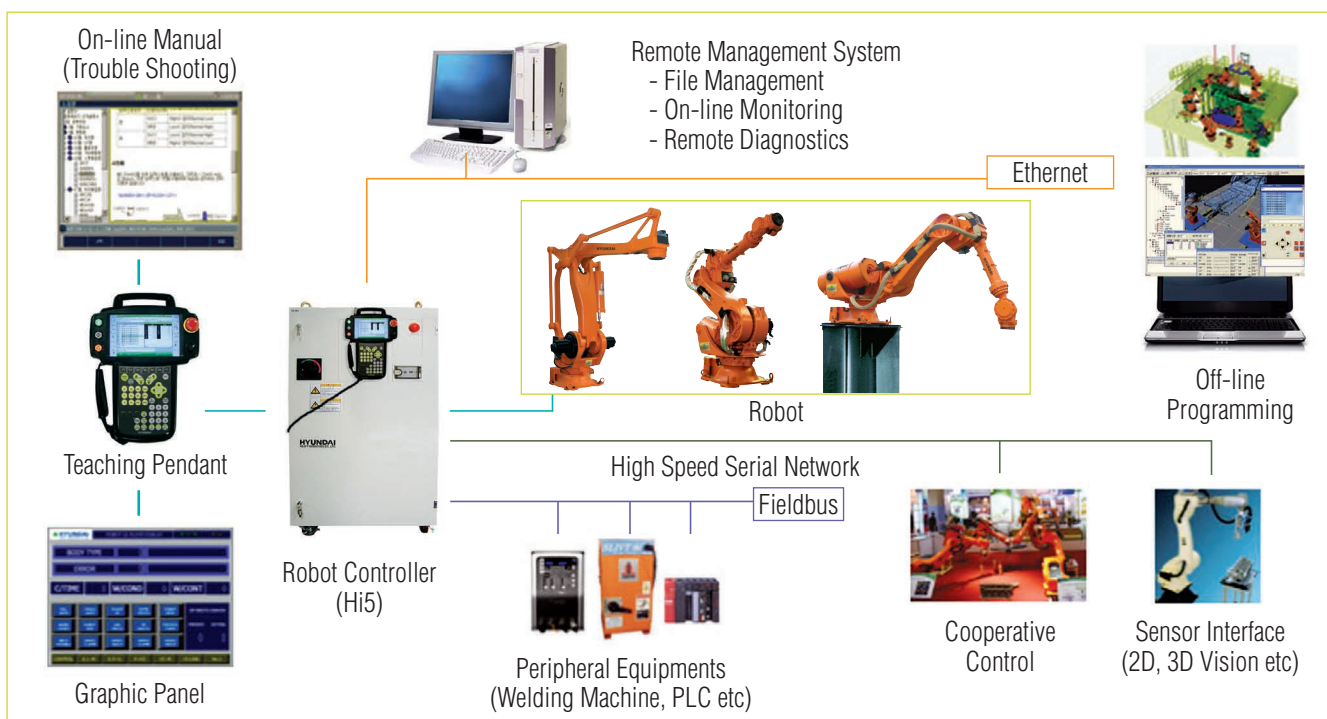



### Key Features

- Enlargement of working envelope by link structure
- Improvement of dynamic performance



### Application

- Palletizing
- Material Handling



## ■ Certificate (ISO 9001, ISO 14001, QS-9000TE, CE) ■

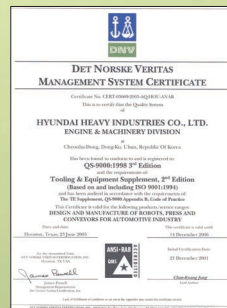

### Korea

#### Head Office

1, Jeonha-dong, Dong-gu, Ulsan  
TEL : 82-52-202-7901~10 / FAX : 82-52-202-7900

#### Seoul Office

140-2, Gye-dong, Jongno-gu, Seoul  
TEL : 82-2-746-4713 / FAX : 82-2-746-4720

#### Ansan Office

1431-2, Sa-dong, Sangnok-gu, Ansan-si, Gyeonggi-do  
TEL : 82-31-409-4945 / FAX : 82-31-409-4946

#### Cheonan Office

355-15, Daga-dong, Cheonan-si, Chungcheongnam-do  
TEL : 82-41-576-4294 / FAX : 82-41-576-4296

#### Daegu Office

223-5, Beomeo 2-dong, Suseong-gu, Daegu  
TEL : 82-53-746-6232~3 / FAX : 82-53-746-6231

#### Gwangju Office

415-2, Nongseong-dong, Seo-gu, Gwangju  
TEL : 82-62-363-5272 / FAX : 82-62-363-5273

### Overseas

#### Chicago / U.S.A

955 Estes Avenue, Elk Grove Village IL  
60007, U.S.A  
TEL : +1 800 423 8721  
FAX : +1 847 437 3574

#### Houston / U.S.A

1400 Broadfield, Suite 110, Park 10  
Center Houston, Texas 77084, U.S.A  
TEL : +1 281 578 7097  
FAX : +1 281 578 8317

#### London / U.K

2ND Floor, The Triangle 5-17,  
Hammersmith Grove London W6 0LG,  
U.K  
TEL : +44 20 8741 0501  
FAX : +44 20 8741 5620/8834 7281

### Rotterdam / Netherland

Folkert Elsingastraat 7  
3067 NW, Rotterdam, The Netherland  
TEL : +31 10 212 1567  
FAX : +31 10 212 5134

### Beijing / China

Beijing Hyundai Jingcheng  
No.2, Nanli, Luguogiao  
Fengtai District, Beijing, China  
TEL : +86 10 8321 2588  
FAX : +86 10 8321 2188

### Mumbai / India

Hyundai Heavy Industries Co., Ltd.  
301, 3rd Floor, Sarjan Plaza 100, Annie  
Besant Road, Worli, Mumbai 400 018,  
India  
TEL : +91 22 2498 6022~7  
FAX : +91 22 2498 0620



<http://www.hyundai-engine.com>  
E-mail : [robot@hhi.co.kr](mailto:robot@hhi.co.kr)

\*Materials and specifications are subject to change without notice