

HS 165S/200S



HS 165S, HS200S

Manipulator Specifications

Item		Specification	
Model		HS165S	HS200S
Payload		165 kg	200 kg
Structure		Articulated	
Degree of freedom		6 Axes	
Max. Motion Range	S Swivel	±180 °	
	H For/Backward	+160 ° ~ -35 °	
	V Up/Downward	±200 °	
	R2 Rotation 2	±180 °	
	B Bending	±130 °	±125 °
	R1 Rotation 1	±360 °	
Max. Speed	S Swivel	105 °/s	95 °/s
	H For/Backward	105 °/s	95 °/s
	V Up/Downward	105 °/s	95 °/s
	R2 Rotation 2	150 °/s	135 °/s
	B Bending	145 °/s	120 °/s
	R1 Rotation 1	220 °/s	190 °/s
Allowable Moment	R2 Rotation 2	105 kgf·m	136 kgf·m
	B Bending	105 kgf·m	136 kgf·m
	R1 Rotation 1	50 kgf·m	72 kgf·m
Repeatability		±0.2 mm	
Ambient Temperature		0 ~ 45 °C (273 ~ 318 K)	
Approximate Weight		1,450 kg	1,500 kg

Working Envelope

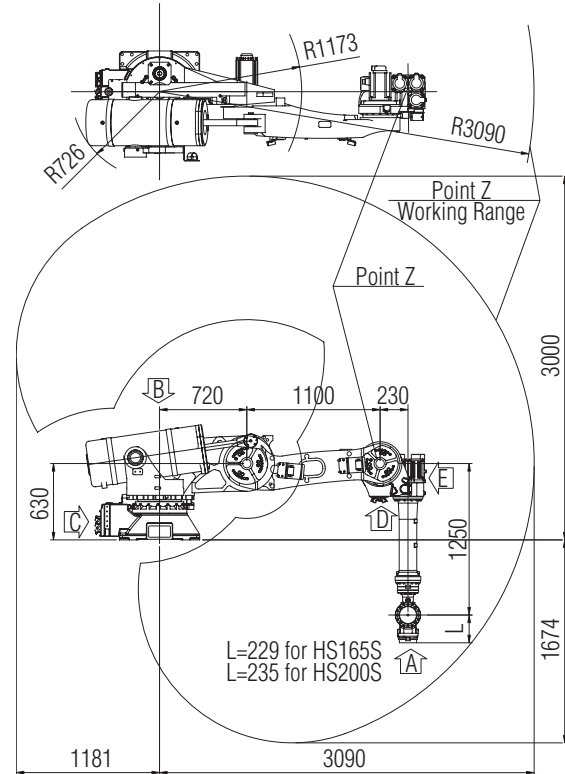

View "A" For Tool Attachment - HS165

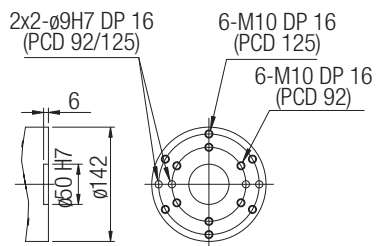

View "A" For Tool Attachment - HS200

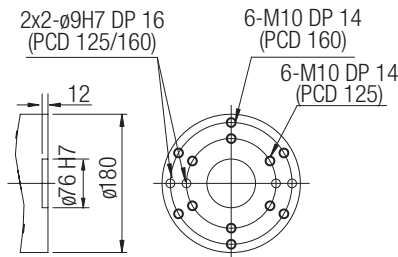

View "B" For Installation

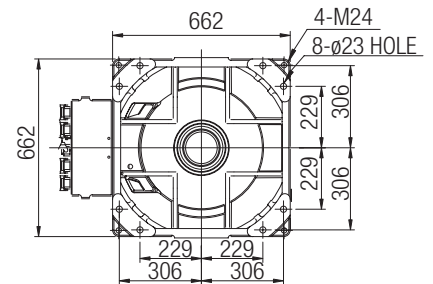

View "C" For User Application

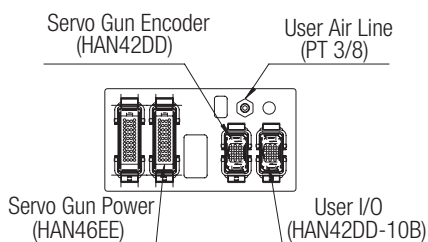

View "D" For User Application

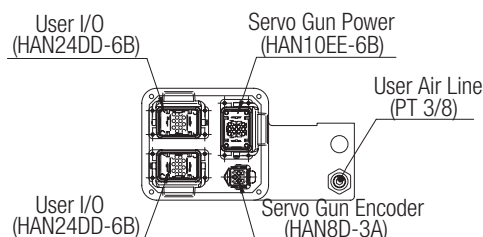

View "E" For Cable Guide

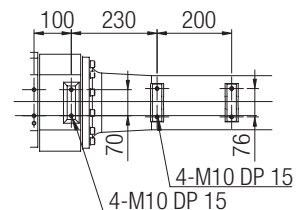

■ Controller Specifications

Item	Specification	
Model Name	Hi5	
Control Hardware	Multi Processor System	
Execution Mode	Teaching & Playback	
Interpolation Type	Point-to-Point, Linear, Circular	
Max. Axes	Max. 16 Axes Simultaneously	
Number of Step	17,000 Points	
External Program Selection	Binary 255 / Discrete 8	
Position Detector	Serial Absolute Encoder	
Program Back-up	USB Memory	
Servo Control	Full Digital Servo	
Digital Input / Output	Max. Input : 256 / Output : 256 Points	
Analog Input / Output	Input : 4 ch / Output : 4 ch	
Conveyor Pulse Counter	Differential Input / Open Collector Input, 2ch	
Communication	Ethernet	100BaseT (2 Ports)
	CAN	User1 / User2
	Serial	RS232C, RS422 (RS485)
	Field Bus	CC-Link, Profibus-DP, Devicenet, Modbus
Rated Supply Voltage	AC220V ± 10%, 50 / 60 Hz	
Max. Rated Power	8 kVA (Instant Max. 30 kVA)	
Cabinet Dimension (WxDxH)	650 mm x 600 mm x 1,100 mm (Except Caster)	
Weight	150 kg (Without Transformer)	
Protection Classification	IP54	
Ambient Temperature	0 ~ 45 °C	

■ Teaching Pendant Specifications

Item	Specification
Microprocessor	32 bits RISC Processor
Operating System	Windows CE
Display	7" Color TFT-LCD
Operation Mode	Menu Driven and Code Input / Touch Panel

· Easy and simple operation

- Easy/convenient programming language similar to BASIC

· Easy maintenance

- Excellent maintenance ability using on-line display function

· Advanced control technology

- Dynamic control
- Advanced vibration suppression control
- Extended torque-velocity control

· Safety

- Compliant with ANSI/RIA15.6_1999 and CE Directives

· Compatibility and connectivity

- Embedded soft PLC
- Fieldbus : CC-Link, Profibus-DP, Devicenet, Modbus, etc.
- Ethernet, Serial Communication

■ System Configuration

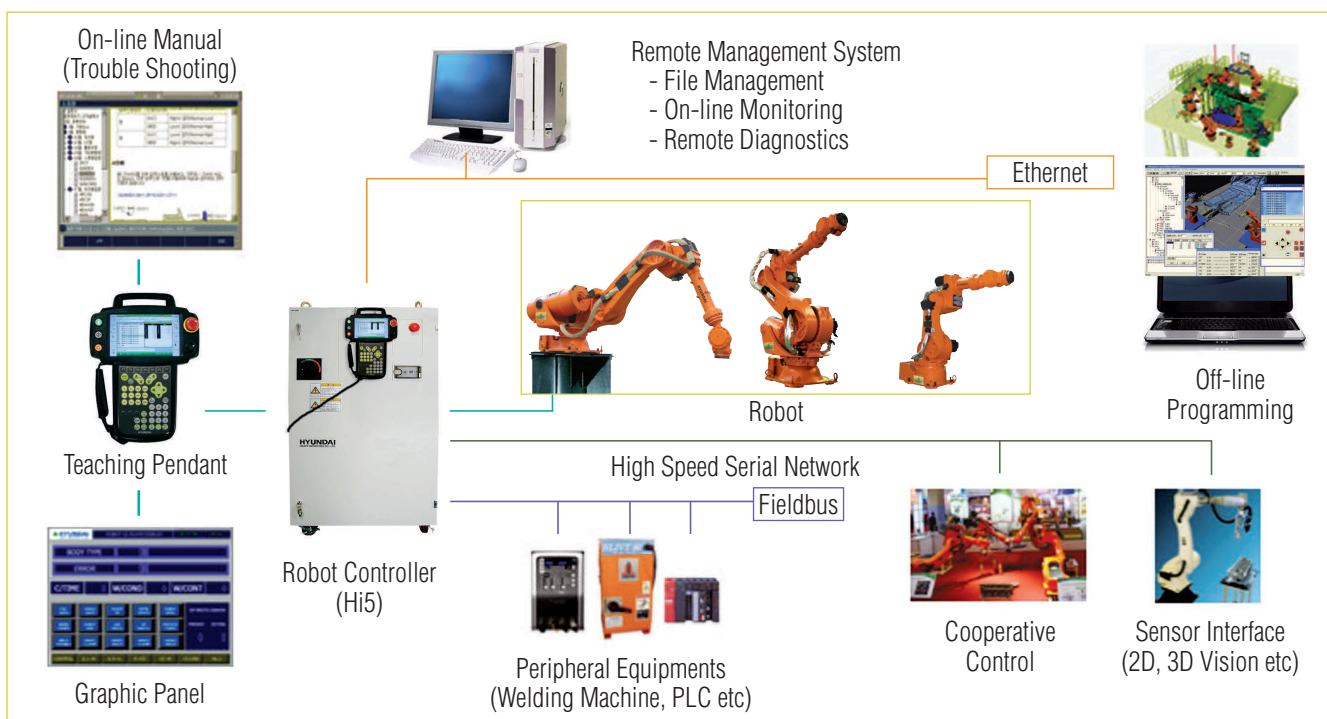



Key Features

- Enlargement of working envelope by serial link structure
- Improvement of dynamic performance

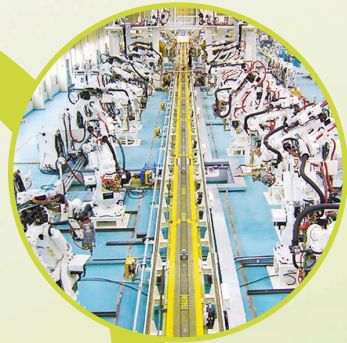

Application

- Spot welding
- Material Handling
- Assembly



■ Certificate (ISO 9001, ISO 14001, QS-9000TE, CE) ■

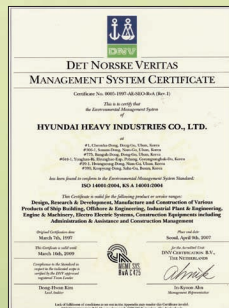

Korea

Head Office

1, Jeonha-dong, Dong-gu, Ulsan
TEL : 82-52-202-7901~10 / FAX : 82-52-202-7900

Seoul Office

140-2, Gye-dong, Jongno-gu, Seoul
TEL : 82-2-746-4713 / FAX : 82-2-746-4720

Ansan Office

1431-2, Sa-dong, Sangnok-gu, Ansan-si, Gyeonggi-do
TEL : 82-31-409-4945 / FAX : 82-31-409-4946

Cheonan Office

355-15, Daga-dong, Cheonan-si, Chungcheongnam-do
TEL : 82-41-576-4294 / FAX : 82-41-576-4296

Daegu Office

223-5, Beomeo 2-dong, Suseong-gu, Daegu
TEL : 82-53-746-6232~3 / FAX : 82-53-746-6231

Gwangju Office

415-2, Nongseong-dong, Seo-gu, Gwangju
TEL : 82-62-363-5272 / FAX : 82-62-363-5273

Overseas

Chicago / U.S.A

955 Estes Avenue, Elk Grove Village IL
60007, U.S.A
TEL : +1 800 423 8721
FAX : +1 847 437 3574

Houston / U.S.A

1400 Broadfield, Suite 110, Park 10
Center Houston, Texas 77084, U.S.A
TEL : +1 281 578 7097
FAX : +1 281 578 8317

London / U.K

2ND Floor, The Triangle 5-17,
Hammersmith Grove London W6 0LG,
U.K
TEL : +44 20 8741 0501
FAX : +44 20 8741 5620/8834 7281

Rotterdam / Netherland

Folkert Elsingastraat 7
3067 NW, Rotterdam, The Netherland
TEL : +31 10 212 1567
FAX : +31 10 212 5134

Beijing / China

Beijing Hyundai Jingcheng
No.2, Nanli, Luguogiao
Fengtai District, Beijing, China
TEL : +86 10 8321 2588
FAX : +86 10 8321 2188

Mumbai / India

Hyundai Heavy Industries Co., Ltd.
301, 3rd Floor, Sarjan Plaza 100, Annie
Besant Road, Worli, Mumbai 400 018,
India
TEL : +91 22 2498 6022~7
FAX : +91 22 2498 0620



<http://www.hyundai-engine.com>
E-mail : robot@hhi.co.kr

*Materials and specifications are subject to change without notice